

INSTALLATION, COMMISSIONING & MAINTENANCE MANUAL

DGS, DGD & DGC-Series
Direct Gas or Nitrogen Bottle Scotch-Yoke Valve Actuators

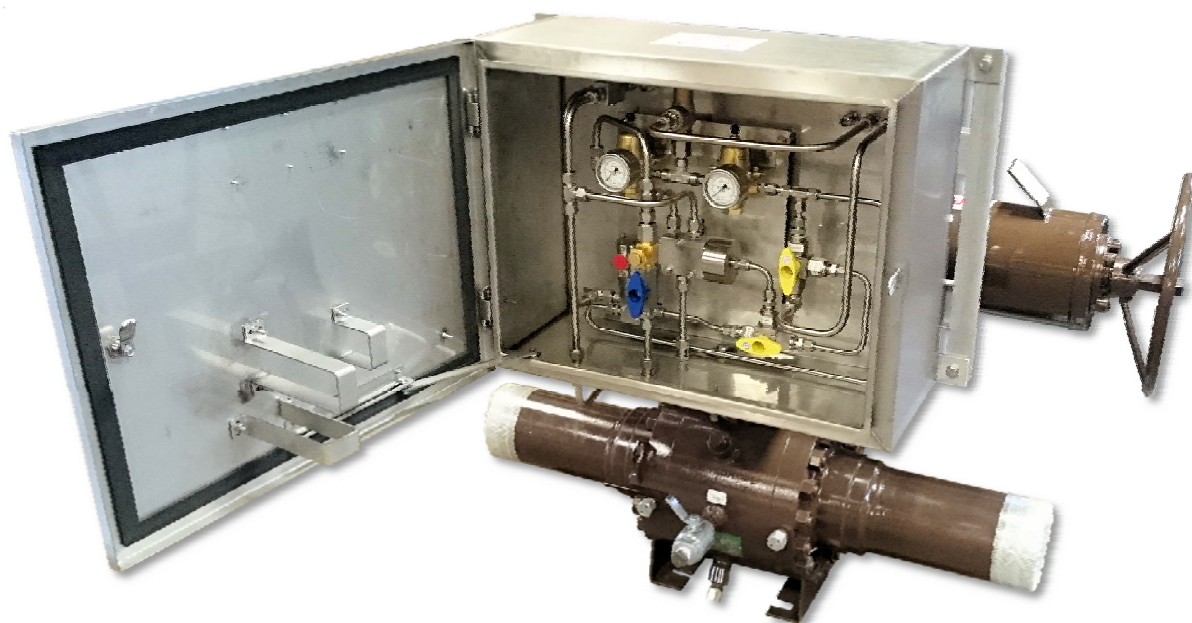

<u>Contents</u>	<u>Page</u>
1. Introduction	3
2. Inspection Requirements on Initial Receipt of Actuator	3
3. Storage Requirements.....	3
3.1 Short-Term Storage	3
3.2 Long-Term Storage	3
4. Actuator Overview	4
4.1 Standard Components	4
4.1.1 Frame.....	4
4.1.2 Direct Gas Cylinder	4
4.1.3 End Stop Screws.....	4
4.1.4 Local Position Indicator	4
4.2 Optional Components	4
4.2.1 Spring Cylinder.....	4
4.2.2 Manual Override.....	5
5. Model Number Designations	5
6. Tool Requirements	5
7. Valve/Actuator Mounting.....	5
8. Adjusting Open and Closed Valve Positions	7
9. Preparations for Start-Up.....	7
10. Manual Override Operation	8
10.1 Double-Acting Actuator with Handwheel Type Manual Override	8
10.2 Double-Acting Actuator with Handpump Type Manual Override.....	8
10.3 Spring Return Actuator with Handwheel Type Manual Override.....	8
11. Maintenance	9
12. Direct Gas Cylinder Seal Replacement	9
13. Lubrication	11
14. Supply Fluid	11
15. Replacement Seal Kits	11
15.1 Direct Gas Spares Kits.....	11
15.2 Frame Spares Kits	11
16. Trouble-Shooting	12
17. Drawings	13
17.1 XXX-XXX-FRXXX-00-002-PL	14
17.2 HYX-XXX-CYXXX-00-001-PL	15
17.3 XXX-XXX-SRXXX-00-001-PL	16
17.4 HY-DA	17
17.5 HY-DA-HW.....	18
17.6 HYX-XXX-HDXXX-00-001-PL.....	19
17.7 HYX-XXX-CYXXX-00-002-PL	20
17.8 HY-SRC	21
17.9 HY-SRC-JS	22
17.10 XXX-XXX-SHXXX-00-001-PL	23
18. Spares Kit Ordering & Additional Service Support	24

IMPORTANT NOTE: DIRECT GAS ACTUATORS CAN BE OPERATED BY GAS SUPPLY LINE OR BY NITROGEN BOTTLES.

1. Introduction

This manual is designed to allow a qualified user to install, commission and maintain Paladon Systems Ltd DGS, DGD and DGC Series valve actuators. This manual should be used in conjunction with any additional documentation supplied at the time of shipping. Current versions of all Paladon Systems Ltd documentation are available from www.paladonsystems.com.

It is the user's responsibility to ensure that all applicable Health and Safety Legislation is followed when undertaking any service work. This manual is not designed to supersede or replace any user's plant safety or work procedures; in the event of any conflict, please contact Paladon Systems Ltd or an authorised distributor.

2. Inspection Requirements on Initial Receipt of Actuator

- Check paint to ensure that no damage has occurred during transit. In the event of any paint damage, thoroughly clean the applicable area(s) and repaint as required.
- Check that the information detailed on the actuator's tag plate (comprises of the actuator serial number, model number, maximum torque output, direct gas supply pressure range and valve tag number) matches those detailed on the Sales Order Acknowledgement, Test Certificates and Delivery Note. In the event of any discrepancies, please contact Paladon Systems Ltd or an authorised distributor.

3. Storage Requirements

3.1 Short-Term Storage

To ensure optimum performance, the following should be undertaken prior to actuator storage for any duration:

- Check that all direct gas and electrical connections are suitably sealed to prevent any environmental ingress.
- For any actuator not yet assembled to a valve, place actuator on a wooden pallet to prevent any damage to the valve coupling flange.

3.2 Long-Term Storage

In addition to the short-term storage requirements detailed above, for long-term storage the following should be undertaken:

- Protect the coupling parts (stem adaptor and coupling joint, coupling flange etc) with grease or protective oil.
- Keep actuators dry and protected against the direct action of weather elements.
- Stroke the actuator and ensure all direct gas and electrical connections are properly sealed after.

4. Actuator Overview

DGS, DGD and DGC Series direct gas valve actuators are suitable for use with quarter-turn valves or mechanisms, and have been designed to provide years of efficient and reliable operation in heavy-duty applications.

The main components of DGS, DGD and DGC Series valve actuators are:

4.1 Standard Components

4.1.1 Frame

The frame contains the scotch-yoke mechanism which converts the linear movement of the direct gas piston into a quarter-turn rotary movement. To protect personnel from injury and the scotch-yoke mechanism from corrosion, the frame is a fully enclosed carbon steel fabricated construction. To support the transverse forces generated by scotch-yoke mechanisms, and to ensure correct alignment of the piston rod, sliding blocks and yoke bushing, the body also contains a chromium plated guide bar.

4.1.2 Direct Gas Cylinder

Contains the direct gas piston, which generates the linear movement which is converted into a quarter-turn rotary movement by the scotch yoke mechanism housed in the actuator body.

4.1.3 End Stop Screws

Allow precise adjustment of a scotch-yoke mechanism's angular stroke by means of two end stop screws. One end stop screw is always located on the end flange of the direct gas cylinder. For double-acting actuators, the remaining end stop screw is either located on the body's blanking flange, or in the event a manual override is fitted, on the manual override. For spring-return actuators, the remaining end stop screw is located on the outer spring-cylinder flange, or in the event a manual override is fitted, on the manual override.

4.1.4 Local Position Indicator

Connected directly to the scotch-yoke mechanism, the local position indicator protrudes through the top of the body to provide precise local visual indication of the actuator's angular position.

4.2 Optional Components

4.2.1 Spring Cylinder

Supplied with all spring-return DGS, DGD and DGC Series valve actuators, the spring cylinder comprises of a scragged pre-compressed spring contained within a fully welded carbon steel container.

WARNING! The spring cylinder is non-serviceable; any attempt to disassemble it may result in serious injury or death.

4.2.2 Manual Override

There are two types of manual override mechanisms which can be provided; Jackscrew or Hydraulic Handpump. Jackscrew type manual overrides comprise of a handwheel and jackscrew to create a linear motion, which is converted to a rotary motion via the scotch-yoke mechanism. Hydraulic handpump manual overrides comprise of a hydraulic cylinder and handpump to create a linear motion, which is converted to a rotary motion via the scotch-yoke mechanism.

5. Model Number Designations

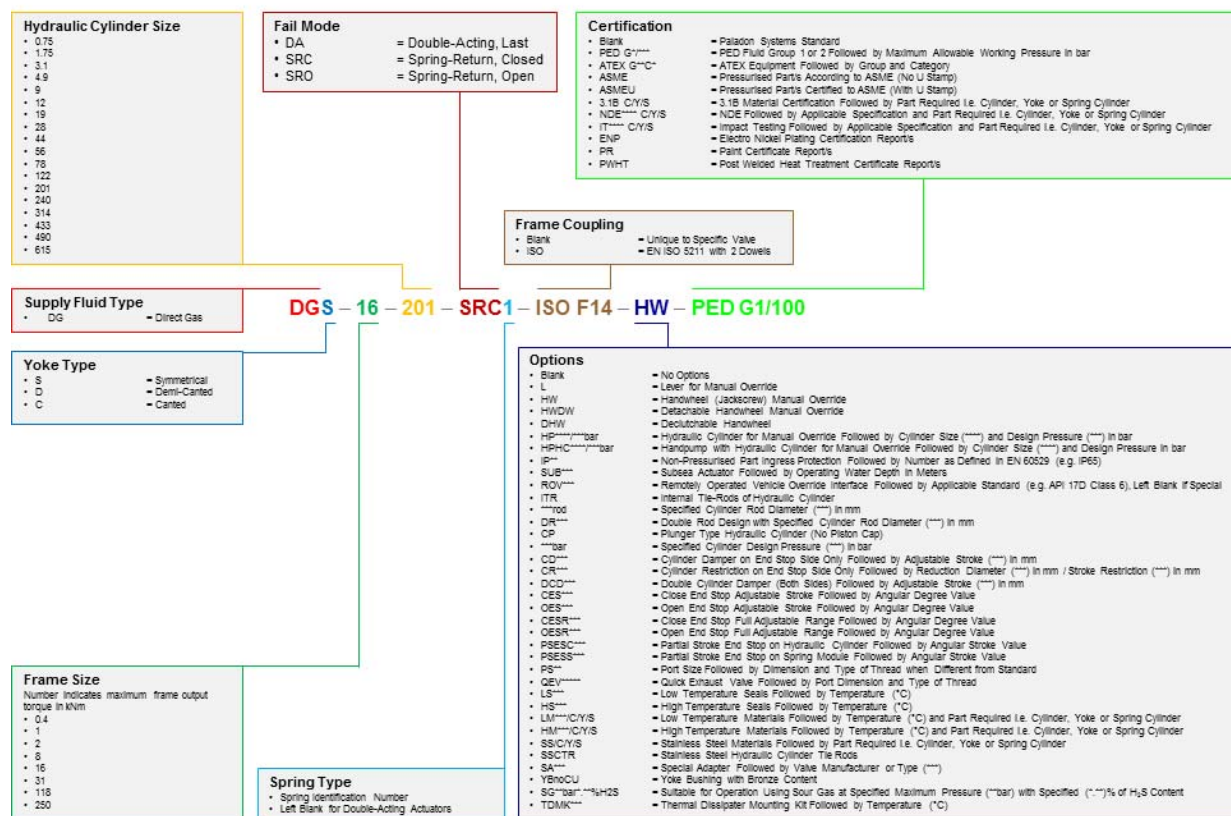

6. Tool Requirements

No special tools are required for the installation, commissioning and maintenance of Paladon Systems Ltd actuators.

7. Valve/Actuator Mounting

Valve mounting is achieved through one of the following:

- Direct mounting using threaded holes on the actuator's body flange.
- Stem adapter mounting using an adapter and coupling joint.

Paladon Systems Ltd actuators can be mounted in any orientation; however, it is common industry practice to align the centreline of the actuator's direct gas cylinder with that of the valve pipework.

NOTE: Certain control components require mounting in a specific orientation with respect to gravity in order to function correctly.

To assemble the actuator to the valve:

- 7.1 Check that the coupling dimensions of the actuator are suitable for those of the valve flange and stem.
- 7.2 Move the valve to the open or closed position to match the rest position of the actuator.
- 7.3 Thoroughly clean all mounting flanges, taking special care to ensure that all grease is removed.
- 7.4 To assist with assembly, lubricate the valve stem with suitable oil or grease.
- 7.5 Lift the actuator by its lifting eyes and, if possible, ensure that the valve stem is in the vertical position.

NOTE: Do not lift the actuator using slings around the actuator's direct gas or spring cylinders; doing so may result in damage.

- 7.6 If valve mounting is via a stem adapter and coupling joint (supplied loose), assemble the coupling joint to the valve stem before proceeding further.
- 7.7 Lower the actuator onto the valve so that the valve stem slips in the actuator's yoke. Fasten the actuator to the valve by means of stud bolts, which are screwed into the valve's coupling flange.
- 7.8 Tighten the nuts to the stud bolts in accordance with the following torques:

Thread Size	Torque
M8	20 Nm
M10	40 Nm
M12	70 Nm
M14	110 Nm
M16	160 Nm
M20	320 Nm
M22	420 Nm
M24	550 Nm
M27	800 Nm
M30	1100 Nm
M33	1400 Nm
M36	1700 Nm

- 7.9 Stroke the actuator to ensure smooth and full opening and closing of the valve.

8. Adjusting Open and Closed Valve Positions

The precise valve open and closed positions are set using the end stop screws. **NOTE: Certain valves incorporate their own end stops. For these types of valves, it is recommended that the valve's end stops be adjusted to their maximum travel so that the valve's end positions are achieved using the actuator's end stop screws only.**

To adjust the open and closed valve positions:

- 8.1 Loosen the protective nut on each of the end stop screws.
- 8.2 Move the actuator yoke away from the applicable end stop screw.
- 8.3 Screw the applicable end stop screw to reduce the actuator's angular stroke, unscrew to increase it.
- 8.4 Move the actuator yoke towards the applicable end stop screw.

NOTE: During actuator stroking, a small loss of gas through the end stop screw located on the direct gas cylinder is to be expected.

- 8.5 Check valve position and repeat steps 2 to 4 until desired valve position is reached.
- 8.6 Tighten the protective nut on the applicable end stop screw.
- 8.7 Repeat steps 8.2 to 8.6 for the remaining end stop screw.

9. Preparations for Start-Up

Direct Gas Connections & Considerations

- 9.1 Prior to connecting the direct gas supply line(s), check that all pipes and fittings are in accordance with the plant specifications.
- 9.2 Check that all direct gas supply lines are free of any contaminants or debris, and that they are suitably supported to minimise any stress caused by vibration.
- 9.3 Connect the direct gas supply line fasteners.
- 9.4 Pressurize direct gas cylinder. Check fasteners for any leaks, and ensure that they are sufficiently tightened to avoid the chance of becoming loose due to any vibrations created during operation.

Electrical Connections & Considerations

NOTE: All electrical connections are the responsibility of the user.

- 9.5 For installations in hazardous areas, ensure all electrical fittings have the correct hazardous area certification.
- 9.6 Ensure that the actuators and any control components are suitably protected against lightning strikes, electrical surges and spikes; and any magnetic fields.

Actuator Stroking

- 9.7 Stroke the actuator to check that smooth and continuous operation is achieved. In the event of uneven stroking, or stroking speeds below those detailed on the test certificate; first check to ensure correct gas supply pressure and flow rate. Further fault finding procedures can be found in Section 16.

10. Manual Override Operation

10.1 Double-Acting Actuator with Handwheel Type Manual Override

(See Section 17.6, Drg. HYX-XXX-HDXXX-00-001-PL)

- a. Isolate direct gas supply, depressurise actuator and control system.
- b. Remove tubing and fittings from actuator supply inlets to ensure that both sides of the piston are free to 'breathe' to atmosphere.
- c. Move the lever on the handwheel frame mounting flange to the 'ENGAGED' position.
- d. Rotate the handwheel clockwise to close, or anti-clockwise to open the valve.
- e. Once the desired valve position has been achieved, disengage the manual override by moving the lever on the handwheel frame mounting flange to the 'DISENGAGED' position.
- f. Re-connect direct gas supply connections.

10.2 Double-Acting Actuator with Handpump Type Manual Override

(See Section 17.7, Drg. HYX-XXX-CYXXX-00-001-PL)

- a. Isolate direct gas supply, depressurise actuator and control system.
- b. Remove tubing and fittings from actuator supply inlets to ensure that both sides of the piston are free to 'breathe' to atmosphere.
- c. Move the 3-way ball valve and cylinder link ball valve levers to the horizontal position.
- d. Move the handpump selector valve to the required flow direction.
- e. Operate handpump until desired valve position is achieved.
- f. Return 3-way ball valve, cylinder link ball valve and handpump selector valves to automatic position.
- g. Re-connect direct gas supply lines.

10.3 Spring Return Actuator with Handwheel Type Manual Override

(See Section 17.10, Drg. XXX-XXX-SHXXX-00-001-PL)

- a. Isolate direct gas supply, depressurise actuator and control system.
- b. Remove tubing and fittings from actuator supply inlet to ensure that both sides of the piston are free to 'breathe' to atmosphere.

- c. Ensure actuator is in its fail position.
- d. Rotate the handwheel anti-clockwise to open the actuator (for fail close 'SRC' actuators) or in clockwise direction to close the actuator (for fail open 'SRO' type actuators).
- e. Before restoring automatic direct gas operation, rotate the handwheel in the opposite direction to the above bullet in order to move the actuator to its fail position.
- f. Reconnect direct gas supply lines.

11. Maintenance

- 11.1 All Paladon Systems Ltd actuators have been designed to provide long service with minimum maintenance; however, a preventative maintenance program is recommended. Preventative maintenance programs not only help avoid unanticipated and costly down time, but also typically reduce the overall cost of ownership.
- 11.2 It is the user's responsibility to ensure that all applicable health and safety legislation is followed when undertaking any maintenance work.
- 11.3 **WARNING! Before commencing any maintenance work, the actuator's direct gas supply line, actuator and associated controls must be fully depressurised. After system depressurisation, the actuator and controls must be isolated from the supply line, and from any remote control signals. Failure to follow any of these steps may result in unanticipated actuator and valve movement, possibly resulting in serious injury or death.**
- 11.4 Any unauthorised maintenance or modification to the actuator and, where applicable, the control system may invalidate the warranty.
- 11.5 Periodic inspection is recommended, specifically;
 - That smooth valve operation is maintained, and within the required stroking time.
 - That there is no external damage to any components.
 - The direct gas supply pressure is kept within the specified range.
 - Direct gas connections do not show any signs of leakage.
 - Paint system remains undamaged.
 - That any dirt or debris is removed from actuator surfaces.

12. Direct Gas Cylinder Seal Replacement

NOTE: Ensure direct gas system is de-pressurised and isolated prior to removing any parts from pressure cylinder.

- 12.1 Remove the bottom flange retaining nuts (see Section 17.2, Drg. HYX-XXX-CYXXX-00-001-PL, Item 8 – commercial part).

- 12.2 Remove the bottom flange (see Section 17.2, Drg. HYX-XXX-CYXXX-00-001-PL, Item 5 – manufactured part).
- 12.3 Slide off the cylinder liner (see Section 17.2, Drg. HYX-XXX-CYXXX-00-001-PL, Item 1 – manufactured part).
- 12.4 Remove the frame cover retaining screws (see Section 17.1, Drg. XXX-XXX-FRXXX-00-002-PL, Item 1 – commercial part).
- 12.5 Remove the frame cover (see Section 17.1, Drg. XXX-XXX-FRXXX-00-002-PL, Item 2 – manufactured part).
- 12.6 Loosen the tie rods (see Section 17.2, Drg. HYX-XXX-CYXXX-00-001-PL, Item 6 – manufactured part).
- 12.7 Unscrew the piston rod and slide it off (see Section 17.2, Drg. HYX-XXX-CYXXX-00-001-PL, Item 3 – manufactured part).
- 12.8 Unscrew the frame fixing screws (see Section 17.2, Drg. HYX-XXX-CYXXX-00-001-PL, Item 10 – commercial part).
- 12.9 Remove the head flange (see Section 17.2, Drg. HYX-XXX-CYXXX-00-001-PL, Item 4 – manufactured part).
- 12.10 Remove the O-rings, the piston scraper, the sliding rings, the gaskets; and clean all O-ring grooves (see Section 17.2, Drg. HYX-XXX-CYXXX-00-001-PL, Items 1, 2, 4, 5 & 6 – commercial part).
- 12.11 Replace all seals with new ones, and ensure that they are lubricated with grease (see Section 17.2, Drg. HYX-XXX-CYXXX-00-001-PL, Items 1, 2, 4, 5 & 6 – commercial part).
- 12.12 Re-assemble the piston rod (see Section 17.2, Drg. HYX-XXX-CYXXX-00-001-PL, Item 3 – manufactured part) by screwing it into the guide block (see Section 17.1, Drg. XXX-XXX-FRXXX-00-002-PL, Item 6 – manufactured part).
- 12.13 Tighten the tie rods (see Section 17.2, Drg. HYX-XXX-CYXXX-00-001-PL, Item 6 – manufactured part).
- 12.14 Re-assemble the cylinder liner (see Section 17.2, Drg. HYX-XXX-CYXXX-00-001-PL, Item 1 – manufactured part) and bottom flange (see Section 17.2, Drg. HYX-XXX-CYXXX-00-001-PL, Item 5 – manufactured part).
- 12.15 Uniformly tighten the bottom flange retaining nuts (see Section 17.2, Drg. HYX-XXX-CYXXX-00-001-PL, Item 8 – commercial part).
- 12.16 Replace the paste gasket of the mechanism cover (see Section 17.1, Drg. XXX-XXX-FRXXX-00-002-PL, Items 1 & 2 – manufactured part).
- 12.17 Replace the frame cover (see Section 17.1, Drg. XXX-XXX-FRXXX-00-002-PL, Item 2 – manufactured part).
- 12.18 Replace and tighten the frame cover retaining screws (see Section 17.1, Drg. XXX-XXX-FRXXX-00-002-PL, Item 1 – commercial part).

12.19 Check for proper actuator operation and for any seal leaks.

13. Lubrication

Usually it is not necessary to lubricate the actuator as all moving parts are lubricated for life; however, in the unlikely event that additional lubrication is required, the following lubricant should be used:

Manufacturer	AGIP
Trade Name	AGIP GR MU EP
Colour	Yellow/Brown
Oil Type	Mineral
Consistency (NLGI Grade) – ASTM D217	1
Worked Penetration at 25°C – ASTM D217	325 dmm
Dropping Point ASTM D2265	185°C
Viscosity of Base Oil at 40°C – ASTM D445	160 mm ² /s

14. Supply Fluid

The supply fluid is the gas coming directly from the pipeline or nitrogen contained in a separate bottle.

15. Replacement Seal Kits

When undertaking any service work, it is strongly recommended that all seals removed during disassembly be replaced. Please refer to the below tables when ordering replacement seal kits:

15.1 Direct Gas Cylinder Spares Kits

Direct Gas cylinder spares kits comprise of the following items:

- Piston Sliding Ring (1 off with 1 off enclosed O-ring)
- Piston Rod Sliding Ring (1 off with 1 off enclosed O-ring)
- Flange O-ring (2 off)
- Piston Rod O-ring (1 off)
- End Stop O-ring (1 off)

For more information regarding the above items, please see Section 17.2, Drg. HYX-XXX-CYXXX-00-001-PL.

15.2 Frame Spares Kits

Frame spares kits comprise of the following items:

- Yoke O-Ring
- Guide Bar O-Ring
- Plug O-Ring
- Bushing O-Ring

For more information regarding the above items, please see Section 17.1, Drg. XXX-XXX-FRXXX-00-002-PL.

NOTE: Each seal kit includes a tube of silicone to replace any paste gaskets seals broken during maintenance.

16. Trouble-Shooting

In the unlikely event of incorrect actuator operation, please refer to the below trouble-shooting guide.

Fault	Cause	Corrective Action
Erratic or slow operation	Supply pressure erratic or below minimum specified pressure.	Check supply pressure and correct as required.
	Worn components.	Disassemble and visually inspect parts for obvious wear and tear, and replace as required.
	Inadequate lubrication.	Disassemble and lubricate as required.
	Defective valve.	Consult with the valve manufacturer.
Short stroke	Incorrect setting of end stops.	Check and adjust position of actuator end stops (see Section 7). Where applicable, check and adjust position of valve end stops.
	Debris in either direct gas cylinder or frame.	Disassemble and remove debris. Check for seal damage and replace as required.
	Defective valve.	Consult with the valve manufacturer.
Insufficient torque output	Supply pressure below specified minimum.	Check supply pressure and correct as required. Check valve torque requirements are in accordance with those specified; if not, consult with valve manufacturer.
	Pipework blocked, crushed or leaking.	Examine pipework; clean or replace as required.
	Defective piston seal.	Disassemble direct gas cylinder, check seals for damage, and replace as required.
	Defective valve.	Consult with the valve manufacturer.

17. Drawings

Section	Drawing	Description
17.1	XXX-XXX-FRXXX-00-002-PL	Frame Assembly
17.2	HYX-XXX-CYXXX-00-001-PL	Direct Gas Cylinder Assembly
17.3	XXX-XXX-SRXXX-00-001-PL	Spring Cylinder Assembly
17.4	HY-DA	Double-Acting Actuator Assembly
17.5	HY-DA-HW	Double-Acting Actuator Assembly with Handwheel Manual Override
17.6	HYX-XXX-HDXXX-00-001-PL	Handwheel Manual Override Assembly for Double-Acting Actuators
17.7	HYX-XXX-CYXXX-00-002-PL	Handpump Manual Override Assembly for Double-Acting Actuators
17.8	HY-SRC	Spring-Return Actuator Assembly
17.9	HY-SRC-JS	Spring-Return Actuator Assembly with Handwheel Manual Override
17.10	XXX-XXX-SHXXX-00-001-PL	Handwheel Manual Override Assembly for Spring-Return Actuators

17.1 XXX-XXX-FRXXX-00-002-PL

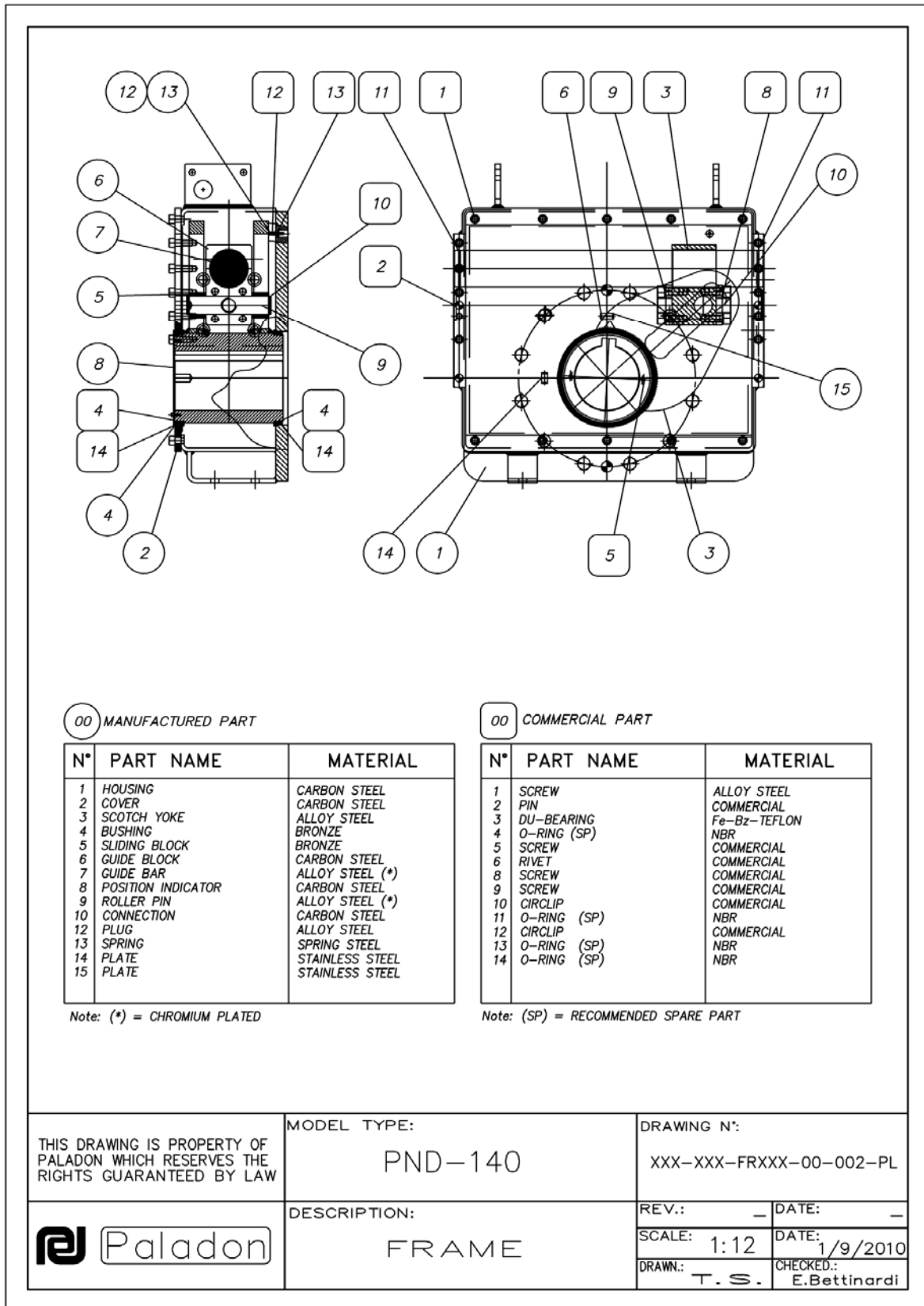

17.2 HYX-XXX-CYXXX-00-001-PL

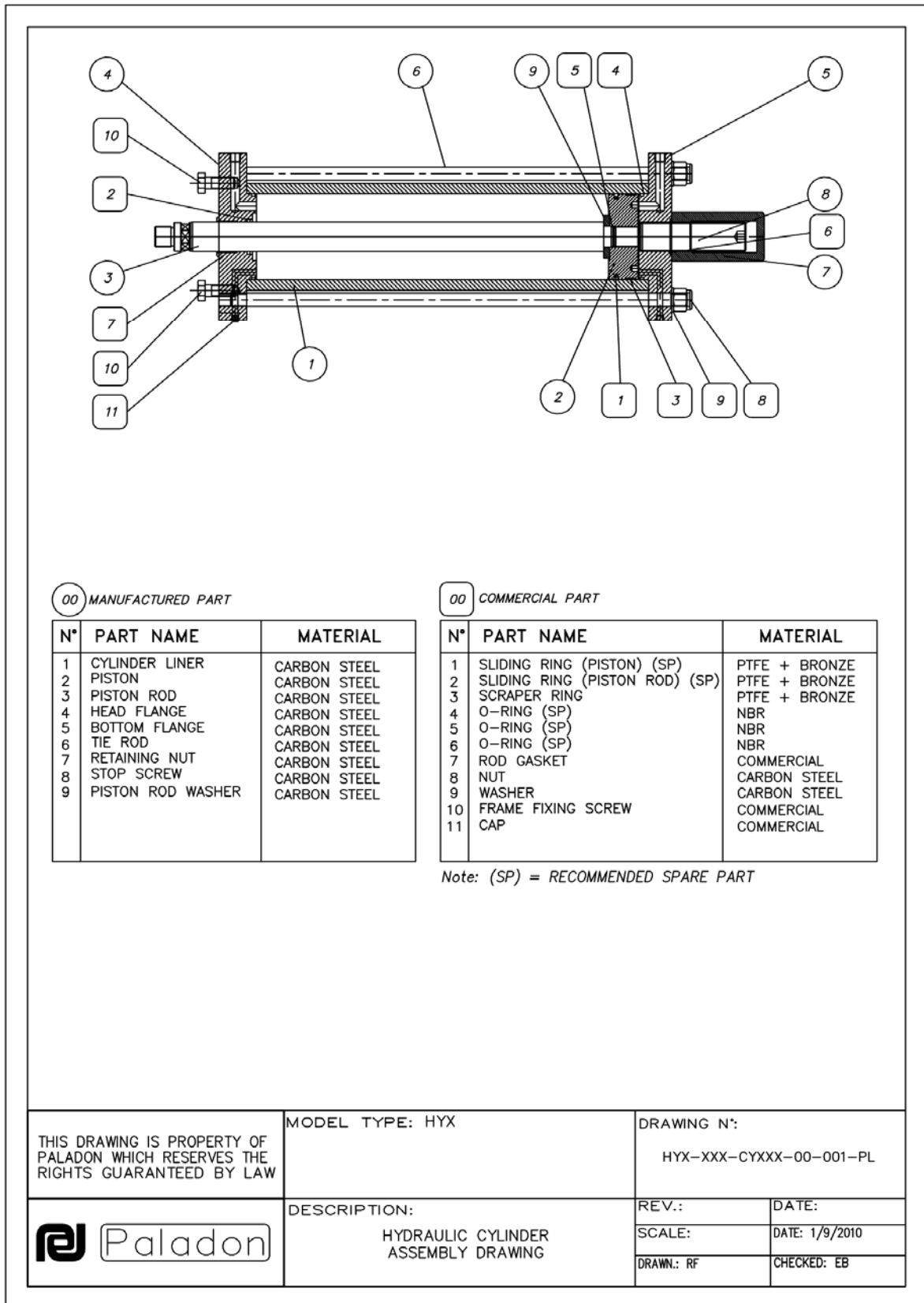

17.3 XXX-XXX-SRXXX-00-001-PL

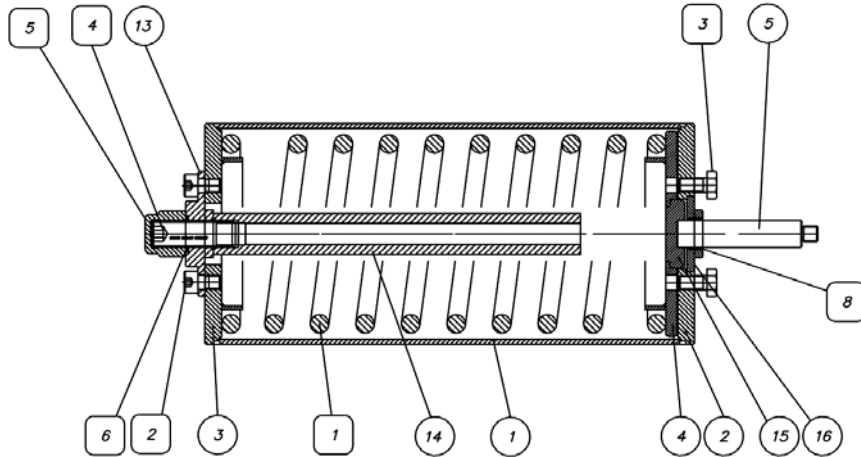

00 MANUFACTURED PART



N°	PART NAME	MATERIAL
1	SPRING LINER	CARBON STEEL
2	SPRING HEAD FLANGE	CARBON STEEL
3	SPRING END FLANGE	CARBON STEEL
4	DISK	CARBON STEEL
5	PUSH BAR	ALLOY STEEL (*)
13	FLANGE	CARBON STEEL
14	STOP GRAIN	CARBON STEEL
15	DISK ADAPTOR	STAINLESS STEEL
16	FLANGE ADAPTOR	STAINLESS STEEL

Note: (*) = CHROMIUM PLATED

00 COMMERCIAL PART

N°	PART NAME	MATERIAL
1	SPRING	SPRING STEEL
2	SCREW	COMMERCIAL
3	SCREW	COMMERCIAL
4	DOWEL	CARBON STEEL
5	CUP	CARBON STEEL
6	O-RING (SP)	NBR
7	SCREW	COMMERCIAL
8	DU-BEARING	Fe-Bz-TEFLON

Note: (SP) = RECOMMENDED SPARE PARTS

THIS DRAWING IS PROPERTY OF PALADON WHICH RESERVES THE RIGHTS GUARANTEED BY LAW 	MODEL TYPE: <p style="text-align: center; font-size: 2em;">CMY</p>	DRAWING N°: <p style="text-align: center;">XXX-XXX-SRXXX-00-001-PL</p>
	DESCRIPTION: <p style="text-align: center;">SPRING CAN N.1</p>	REV.: _ DATE: _ SCALE: 1:4 DATE: 1/9/2010 DRAWN.:  CHECKED.: E.Bettinardi

17.4 HY-DA

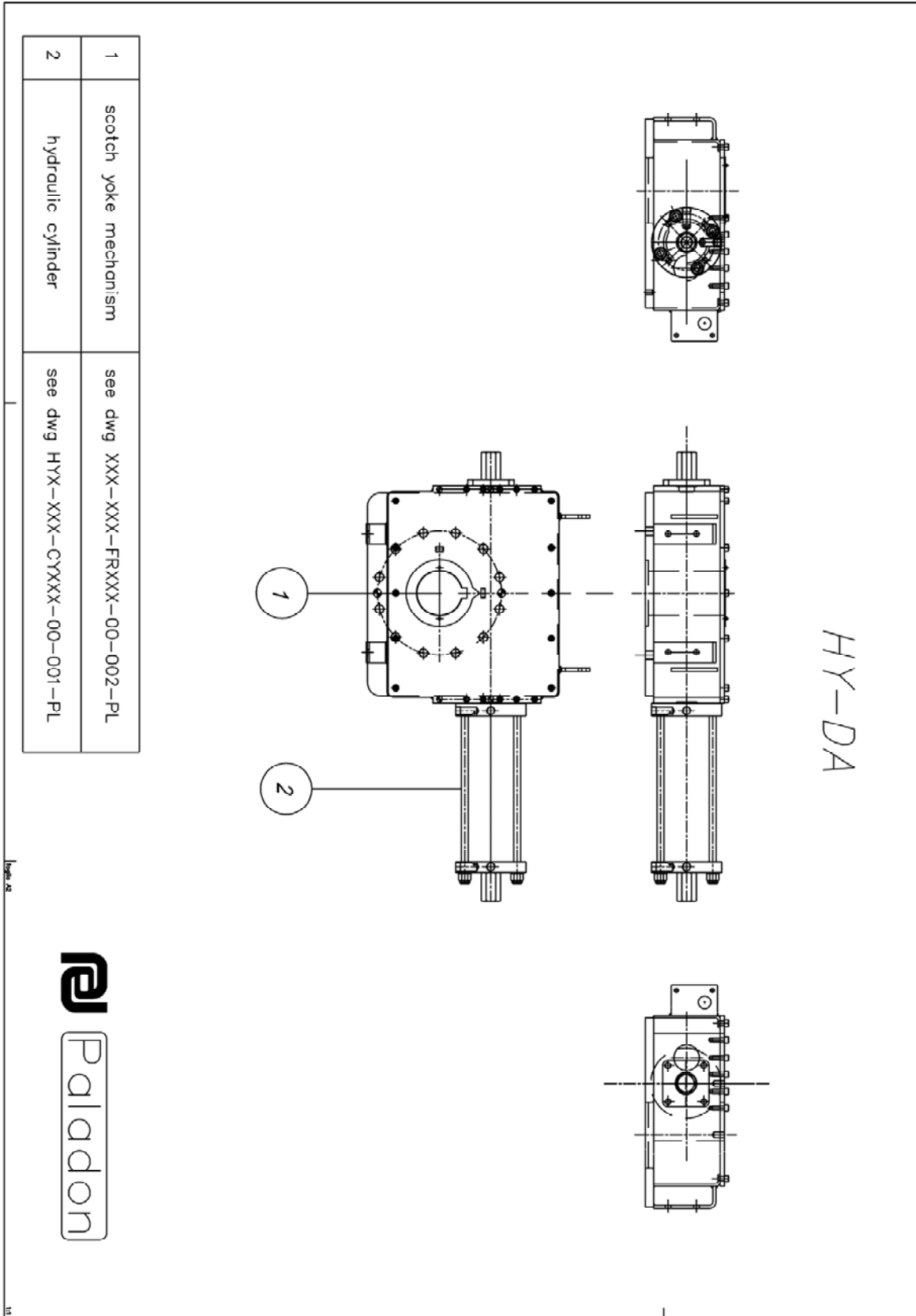

17.5 HY-DA-HW

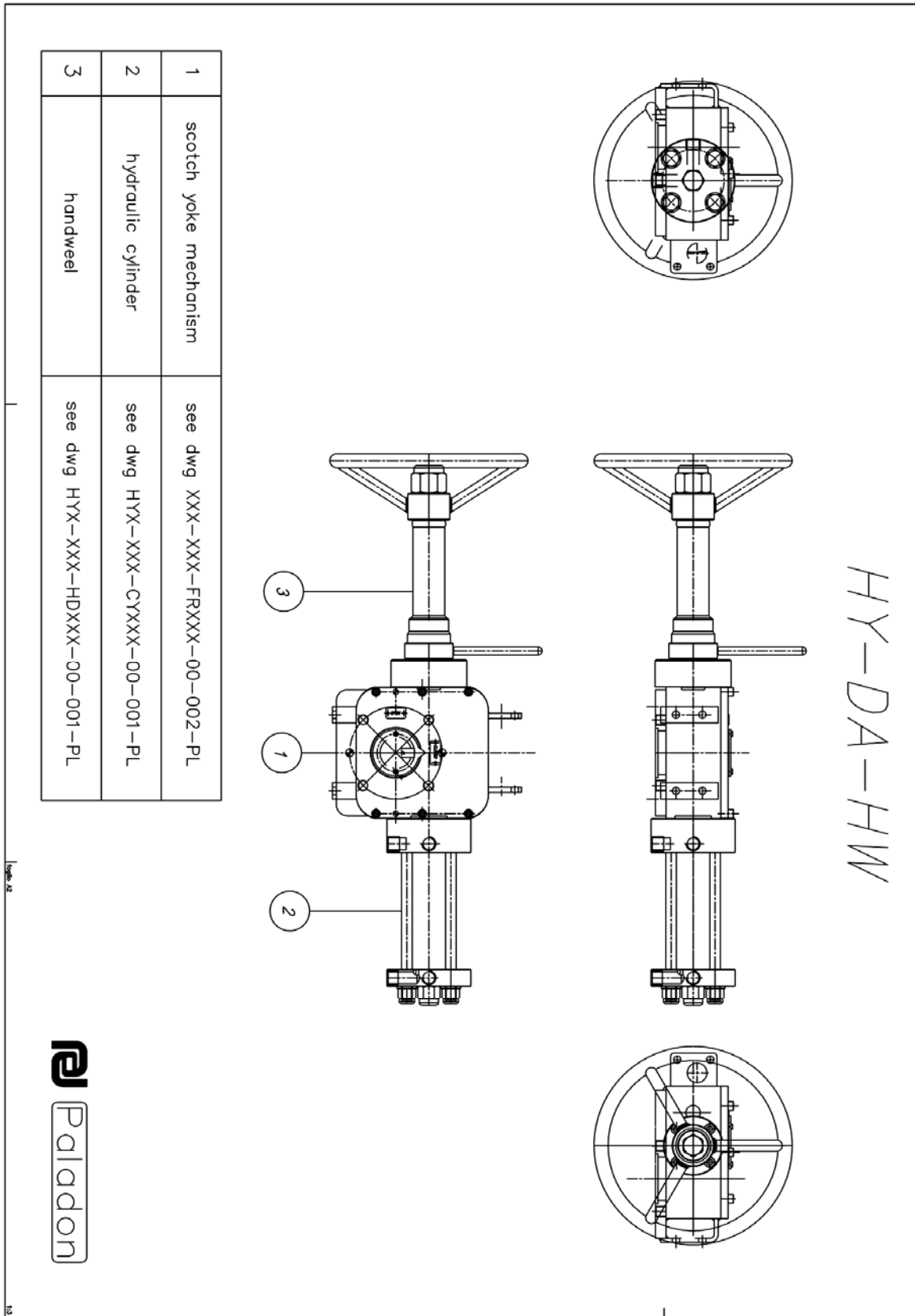

17.6 HYX-XXX-HDXXX-00-001-PL

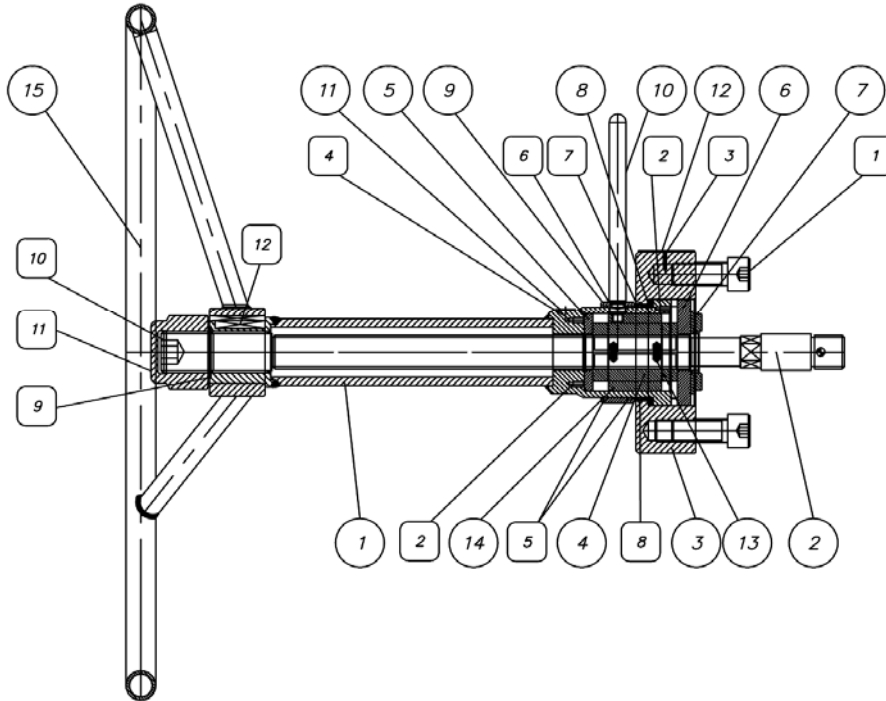

00 MANUFACTURED PART



N°	PART NAME	MATERIAL
1	SLEEVE	CARBON STEEL
2	SCREW	CARBON STEEL
3	FLANGE	CARBON STEEL
4	SPLIT NUT	CARBON STEEL
5	FLANGE	CARBON STEEL
6	DISK	CARBON STEEL
7	BUSHING	BRONZE
8	BUSHING	BRONZE
9	RING	CARBON STEEL
10	HAND GRIP	CARBON STEEL
11	NAME PLATE	AISI303
12	NAME PLATE	AISI303
13	SPRING	CARBON STEEL
14	ECCENTRIC	AISI 420F
15	WHEEL	CARBON STEEL

Note: (*) = CHROMIUM PLATED

00 COMMERCIAL PART

N°	PART NAME	MATERIAL
1	SOCKET HEAD SCREW	COMMERCIAL
2	PIN	COMMERCIAL
3	RIVET	COMMERCIAL
4	RIVET	COMMERCIAL
5	O-RING (SP)	NBR
6	O-RING (SP)	NBR
7	O-RING (SP)	NBR
8	O-RING (SP)	NBR
9	O-RING (SP)	NBR
10	STOP GRAIN	CARBON STEEL
11	STOP NUT	CARBON STEEL
12	KEY	COMMERCIAL

Note: (SP) = RECOMMENDED SPARE PARTS

THIS DRAWING IS PROPERTY OF PALADON WHICH RESERVES THE RIGHTS GUARANTEED BY LAW 	MODEL TYPE: H W - D A	DRAWING N°: HYX-XXX-HDXXX-00-001-PL
	DESCRIPTION: MANUAL OVERRIDE	REV.: - SCALE: 1:2.5 DRAWN.: 

17.7 HX-XXX-CYXXX-00-002-PL

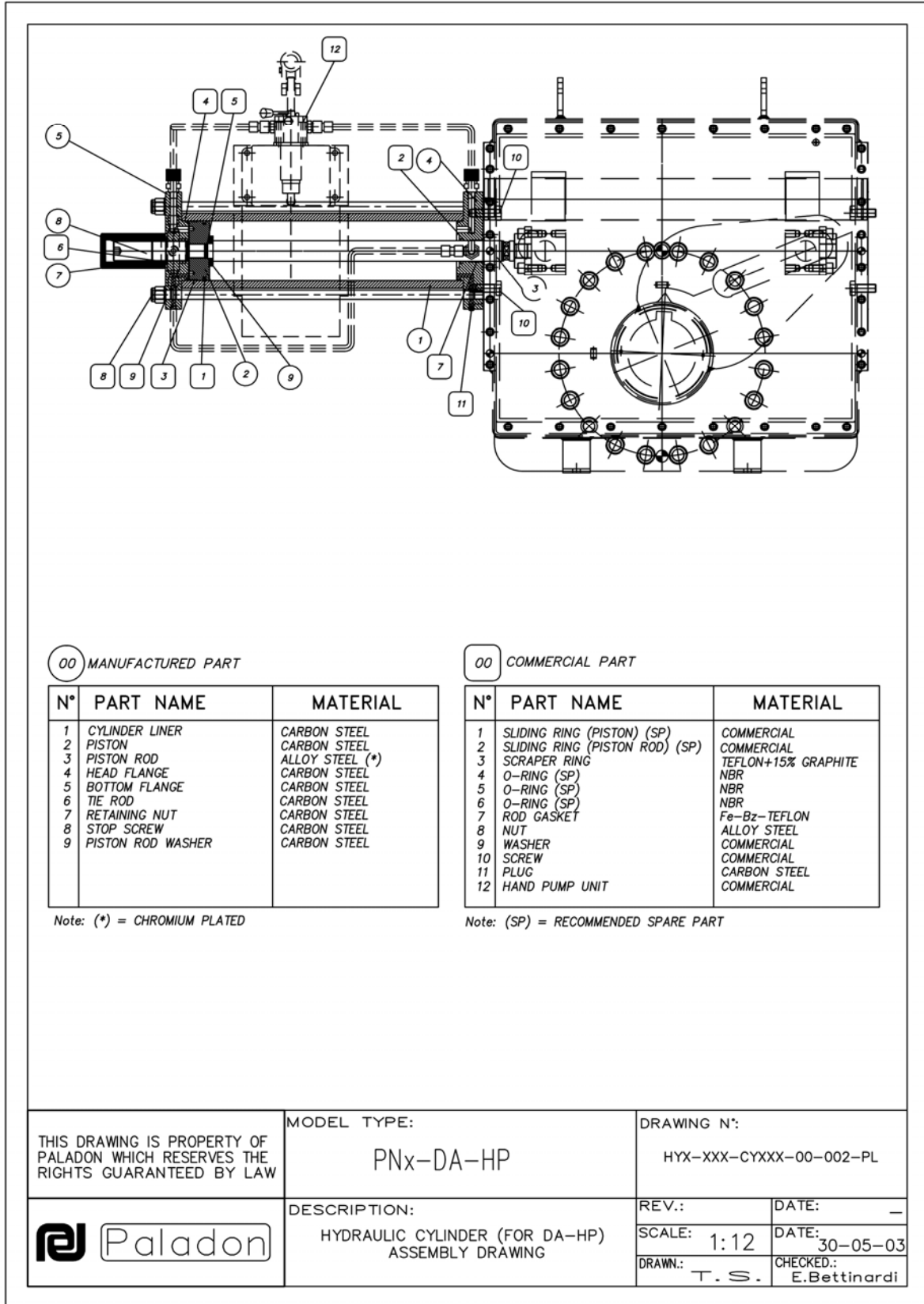

17.8 HY-SRC

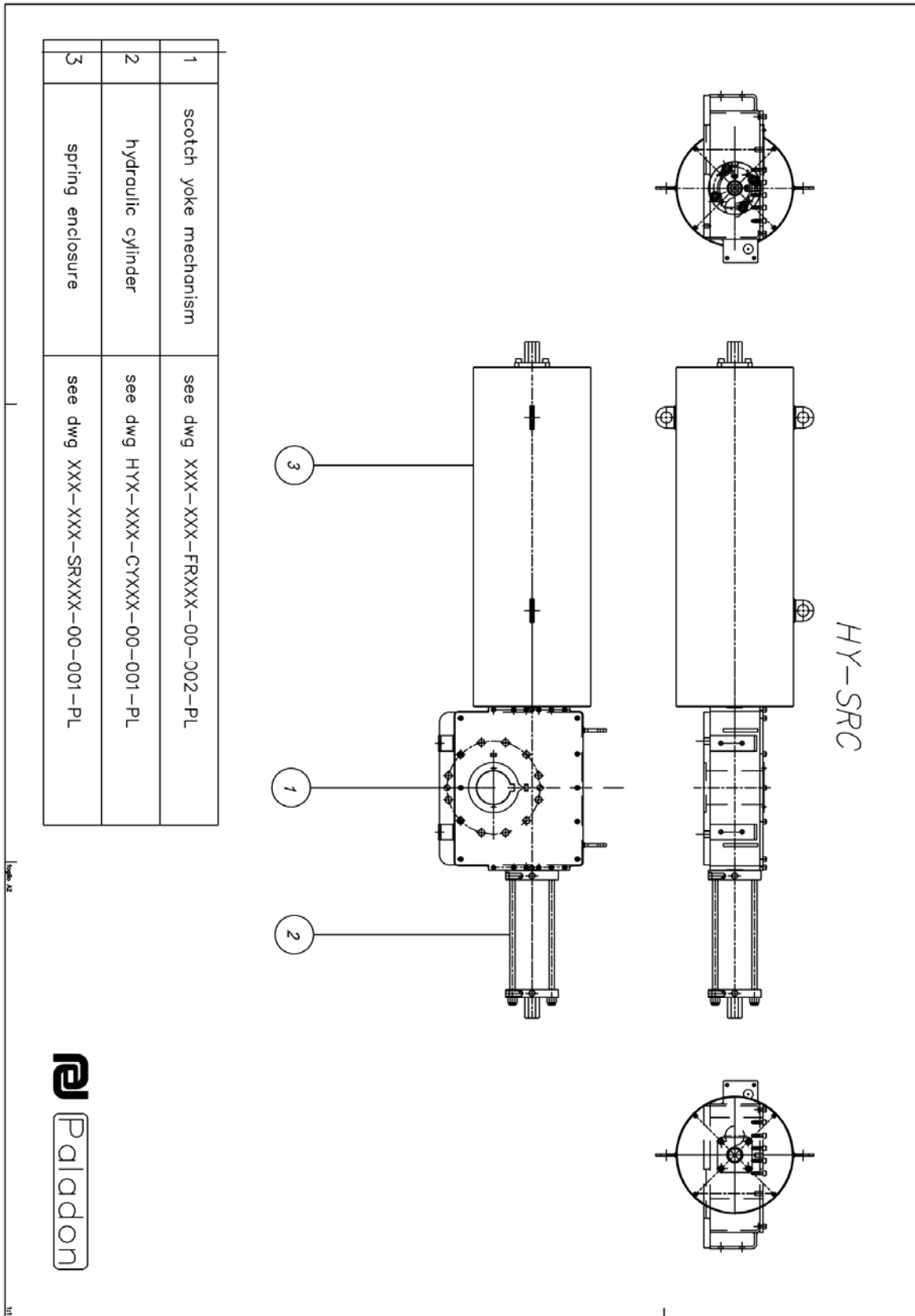

17.9 HY-SRC-JS

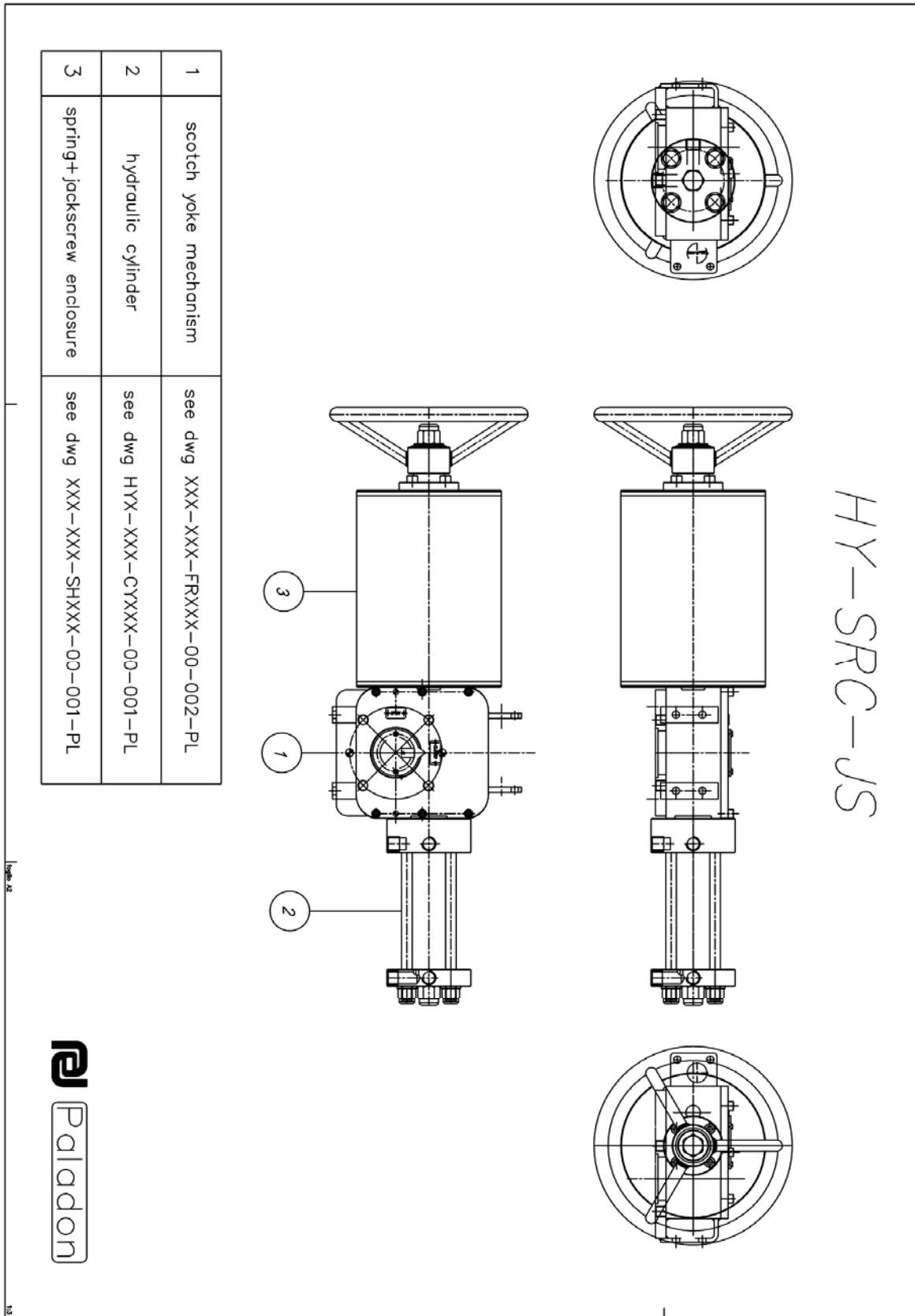

17.10 XXX-XXX-SHXXX-00-001-PL

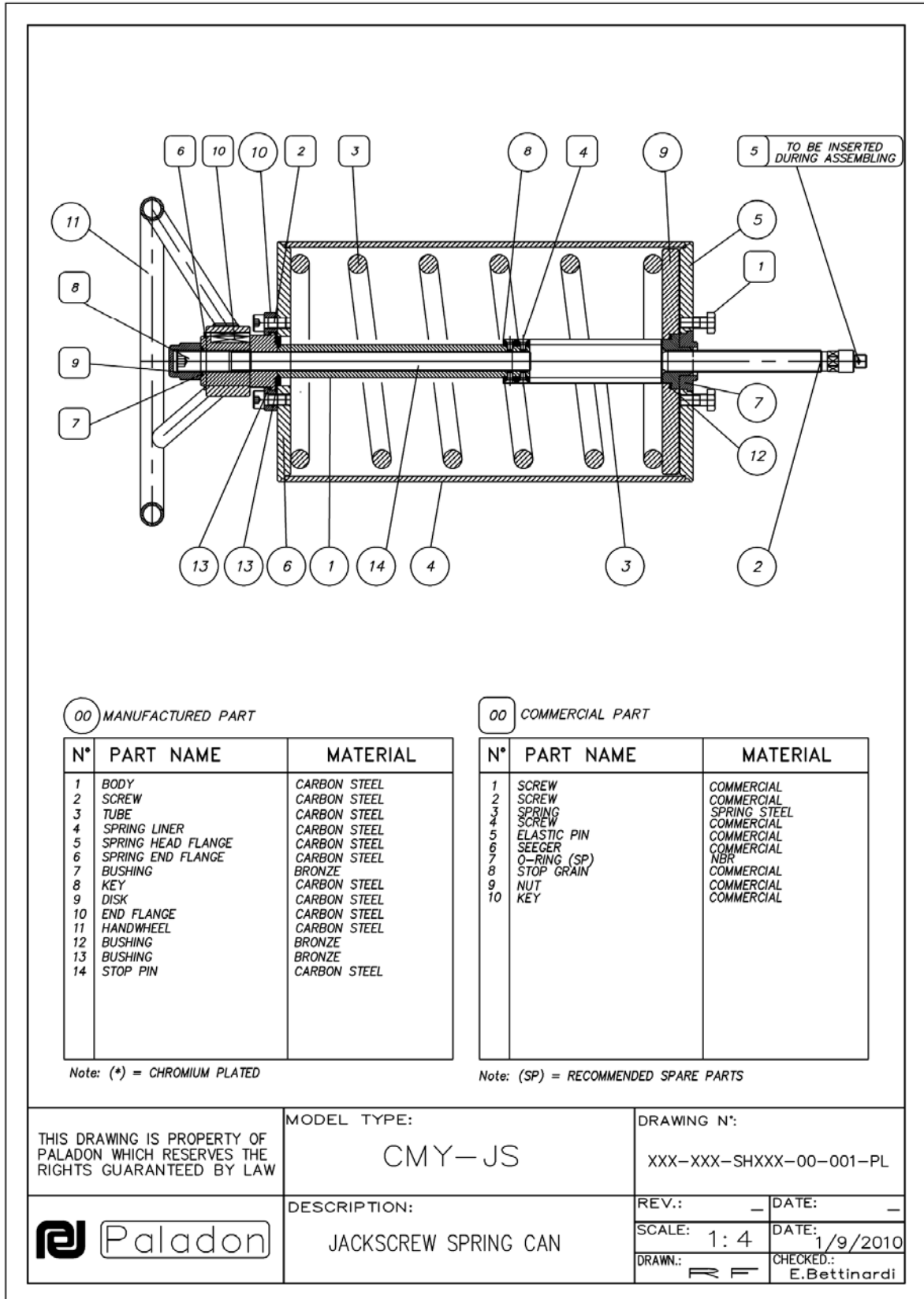

18. Spares Kit Ordering & Additional Service Support

When requesting service support or ordering spares kits, please provide the following contract details:

- Actuator Serial Number (6 or 7 digit number with a RFPL prefix)
- Paladon Contract Number (5 digit number with an ACCP, ACE, ACP, ACSP, CCP, CE, CGH, CP, CPC or CSP prefix)
- General Arrangement or Control Schematic Drawing Number
- Full Actuator Model Number(s) and Descriptions
- Tag Number(s)

Please contact your nearest Paladon representative as detailed below:

- **Paladon Systems Ltd**
Ferro Fields, Brixworth, Northampton, NN6 9UA, England
Tel: +44 (0)1604 880700 Fax: +44 (0)1604 882424
info@paladonsystems.com
- **Paladon Systems Ltd**
Kings Point House, Unit 4, Kingshill Park, Venture Drive, Arnhill Business Park, Westhill, Aberdeen, Scotland, AB32 6FL
Tel: +44 (0)1224 772442
info.scotland@paladonsystems.com
- **Paladon Italia**
Via Barbieri, 24, 27040 Pinarolo Po, PV, Italy
Tel: +39 0383 878524 Fax: +39 0383 878042
info.italia@paladonsystems.com
- **Paladon SDT**
121352 Davydkovskaya Str. 12/3. Moscow, The Russian Federation
Tel/Fax: +7 495 735 28 07 (08) (09)
info.russianfederation@paladonsystems.com
- **Paladon Systems Sdn Bhd**
Asia Pacific Region
No. 8 Jalan Serendah 26/39, Seksyen 26, 40400 Shah Alam, Selangor Darul Ehsan, Malaysia
Tel: +603 5614 3211 Fax: +603 5614 4511
info.asiapacific@paladonsystems.com
- **Paladon Americas**
14514 Luthe Road, Houston, TX 77039, USA
Tel: +1 855 725 2366 Fax: +1 832 310 2370
info.usa@paladonsystems.com
- www.paladonsystems.com